

D313

— ELECTRICAL AND
VIBRATING WIRE
CRACKMETERS

EXTENSOMETERS
& JOINTMETERS



ELECTRICAL AND VIBRATING WIRE CRACKMETERS

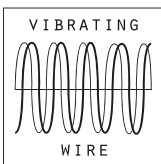
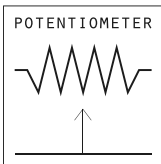

Crackmeters are designed to monitor movements across surface joints or cracks, mainly in concrete structures or rock.

A crackmeter consists of a vibrating wire or potentiometric displacement transducer housed in a stainless steel telescopic body with two anchoring points.

The anchors are fitted with self-lubricating ball joints that allow small lateral movements up to $\pm 10^\circ$ in the orthogonal planes (Y and Z axes), without affecting the operation of the crackmeter.

APPLICATIONS

- Cracks in concrete structures or rock
- Structural joints, such as in concrete dams
- Displacements in pile bearing areas
- Monitoring of rock faults

FEATURES

- 3-D mounting kit available for triaxial displacement monitoring
- Ball joints allow small lateral movements
- Suitable for long-term monitoring

 Meets the essential requirements of the EMC Directive 2014/30/EU

VIBRATING WIRE CRACKMETERS

MODEL	0D313S025VW	0D313S050VW	0D313S100VW	0D313S150VW
Measurement principle	vibrating wire with built-in thermistor			
Range	0 - 25 mm	0 - 50 mm	0 - 100 mm	0 - 150 mm
Accuracy Pol. MPE ⁽¹⁾	< ±0.50% FS	< ±0.30% FS	< ±0.30% FS	< ±0.30% FS
Output signal	frequency (displacement), resistance (thermistor)			
Sensitivity ⁽²⁾	see calibration report			
Displacement resolution	0.02% FS (with Sisgeo readout)			
Typical frequency range ⁽³⁾	1500 to 2800 Hz			
Power supply	-			
Operating temperature	-20°C to +80°C			
Anchors type	expanding shell anchor, Ø 14 mm, 55 mm long			
Length (compressed)	293 mm	360 mm	460 mm	621 mm
Length (extended)	318 mm	410 mm	560 mm	771 mm
Material	stainless steel	stainless steel	stainless steel	stainless steel
Weight	0.5 kg	0.6 kg	0.7 kg	0.8 kg
IP grade	IP68 up to 100 kPa (tested under static conditions; higher values on request)			
Signal cable	0WE104K00ZH			
Max. distance to datalogger ⁽⁴⁾	1000 m (for more information, see FAQ#77)			

(1) MPE is the Maximum Permitted Error over the full scale range (FSR). In the Calibration Report, the accuracies of the gauge are calculated using both linear regression and polynomial correction (\leq Pol. MPE)
 (2) Sensitivity is a specific parameter and is different for each gauge. Sensitivity is determined during the gauge calibration test and reported in the Calibration Report. (3) The expressed frequency range could have a $\pm 10\%$ variation (4) Refer to the FAQ section of the Sisgeo website: www.sisgeo.com/assistance/faq.html

PHYSICAL FEATURES

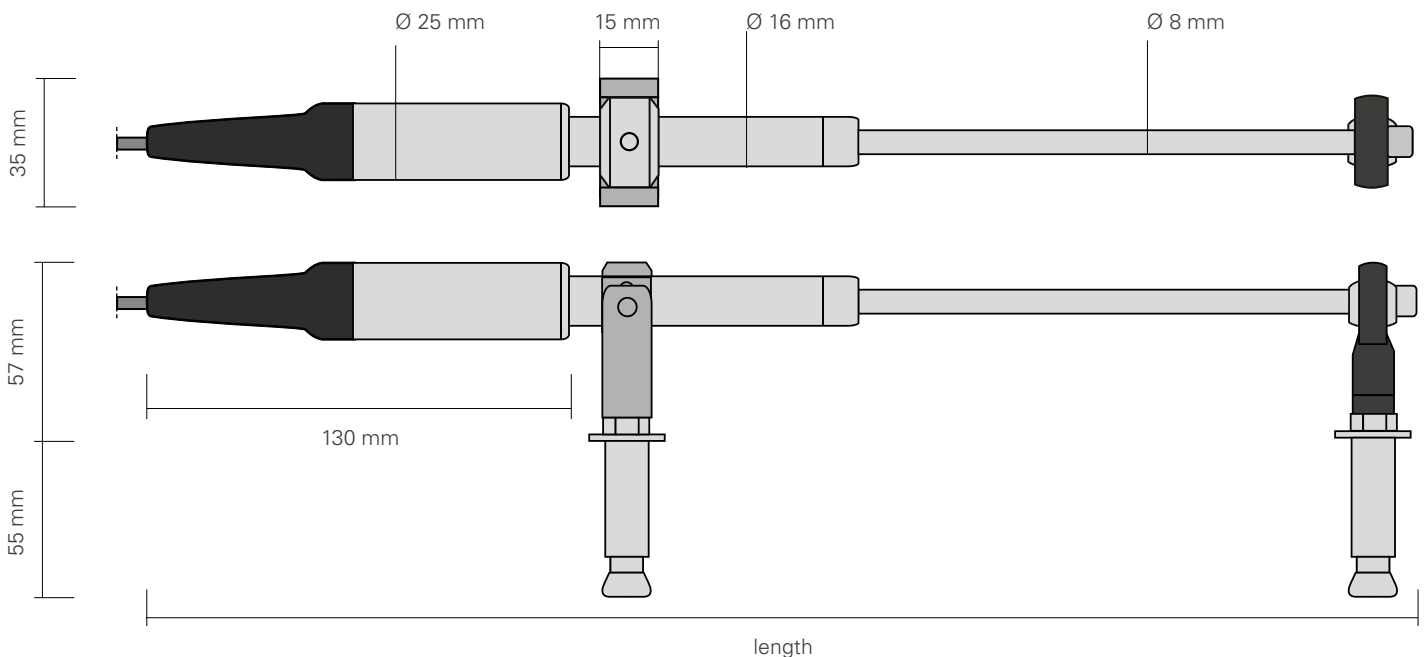

ELECTRICAL CRACKMETERS

MODEL	OD313SA1000	OD313SA2500	OD313SA5000	OD313SAE100	OD313SAE150	OD313SAE200
Measurement principle	linear potentiometer					
Range	10 mm	25 mm	50 mm	100 mm	150 mm	200 mm
Accuracy						
Pol. MPE ⁽¹⁾	< ±0.50% FS	< ±0.30% FS	< ±0.20% FS	< ±0.20% FS	< ±0.15% FS	< ±0.15% FS
Output signal	4-20 mA current loop (voltage version on request)					
Resolution	0.01% FS (with Sisgeo readout)					
Power supply	12 to 24 V DC					
Sensitivity ⁽²⁾	see calibration report					
Operating temp.	-20°C to +60°C					
Anchors type	expanding shell anchors, Ø 14 mm, 55 mm long					
Length (compressed)	334 mm	334 mm	384 mm	484 mm	584 mm	684 mm
Length (extended)	344 mm	359 mm	434 mm	584 mm	734 mm	884 mm
Material	stainless steel					
Weight	0.5 kg	0.5 kg	0.6 kg	0.7 kg	0.8 kg	0.9 kg
IP grade	IP68 up to 100 kPa (tested under static conditions; higher values on request)					
Signal cable	0WE102KEOZH					
Max. distance to datalogger ⁽³⁾	1000 m (for more information, see FAQ#77)					

(1) MPE is the Maximum Permitted Error over the full scale range (FSR). In the Calibration Report, the accuracies of the gauge are calculated using both linear regression and polynomial correction (\leq Pol. MPE)

(2) Sensitivity is a specific parameter and is different for each gauge. Sensitivity is determined during the gauge calibration test and reported in the Calibration Report.

(3) Refer to the FAQ section of the Sisgeo website: www.sisgeo.com/assistance/faq.html

PHYSICAL FEATURES

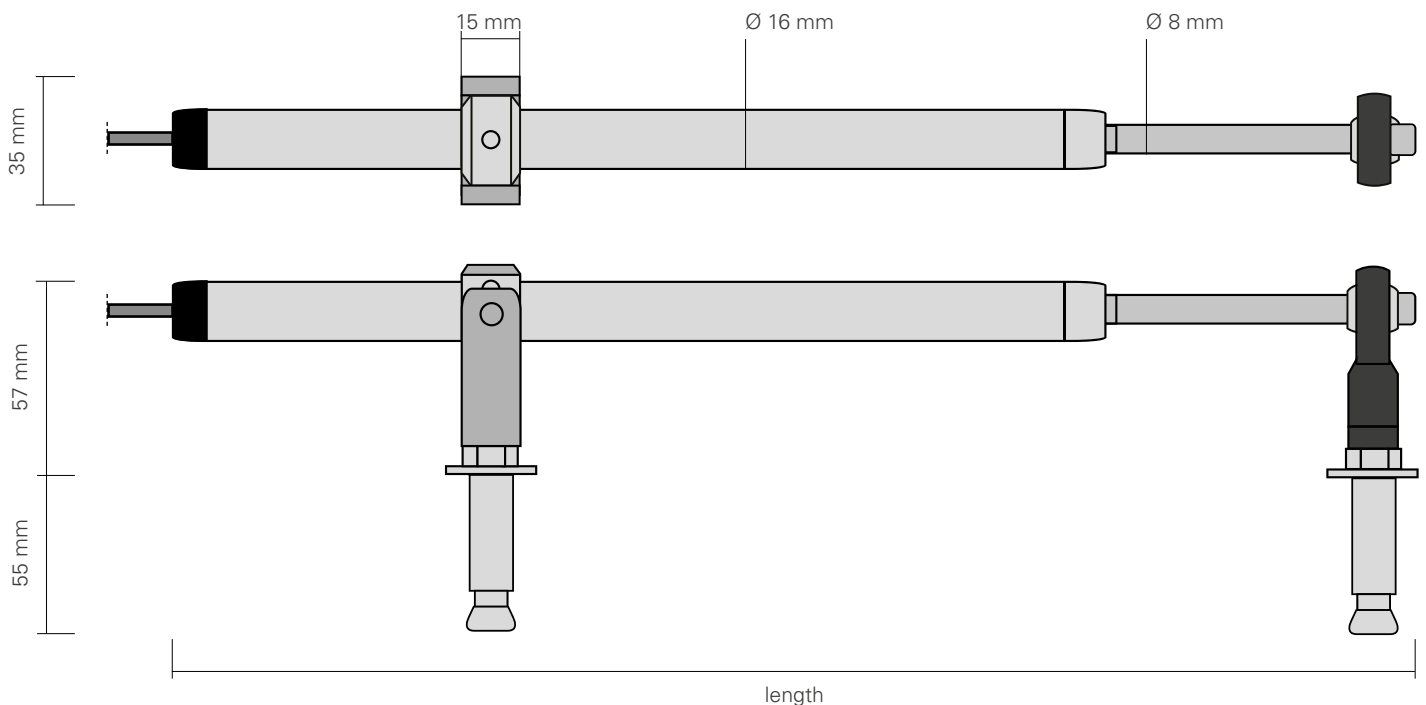

ACCESSORIES AND SPARE PARTS

Y-AXIS FIXING KIT OD31Y1DTE00

Y-axis fixing kit is composed of a stainless steel L-shaped plate (50x50x150 mm) supplied with screws, nuts and expanding shell anchors, allowing crackmeter installation in the Y direction

Z-AXIS FIXING KIT OD31Z1DTE00

Z-axis fixing kit is composed of two stainless steel L-shaped plates (50x60x200 mm and 50x50x65 mm) supplied with screws, nuts and expanding shell anchors, allowing crackmeter installation in the Z

EXTENSION ROD OD313A15000

Stainless steel extension rod for increasing anchor spacing by 150 mm.

16 PAIRS MULTICORE CABLE OWE1320LSZH

Multicore cable (32 wires, 24 AWG) with LSZH M1 outer jacket for grouping up to 4 vibrating wire crackmeters or 8 electrical crackmeters.

CRACKMETER SUPPORT KIT (SPARE) OD313ANCKIT

Spare supports for one crackmeter. The kit includes two anchors, one rod tip support, and one body support.

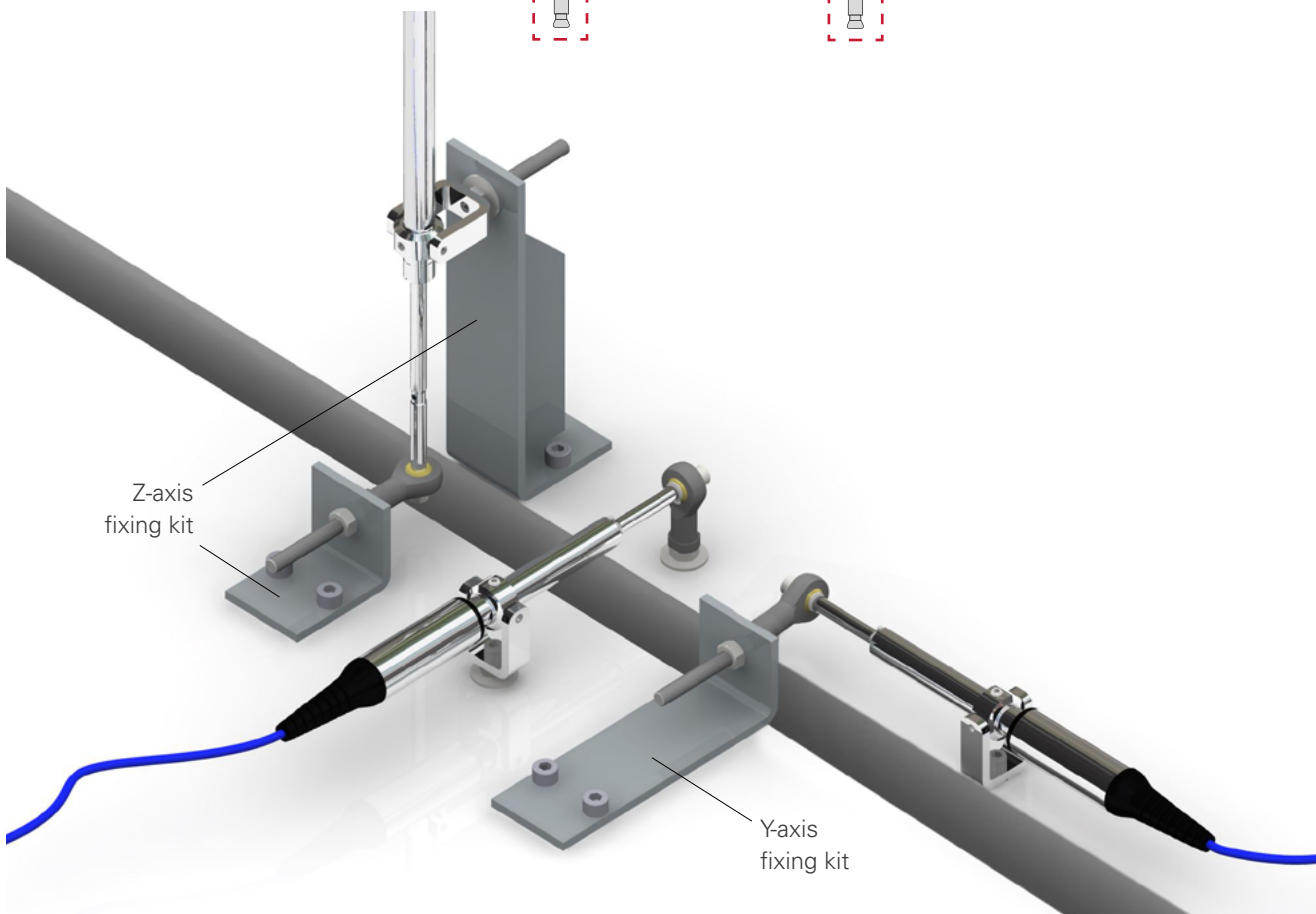
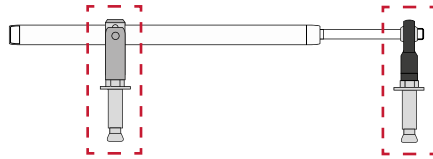

**ANALOG AND WIRELESS
STRUCTURAL MONITORING**

**EXAMPLE OF 3-D APPLICATION:
PILE BEARING DISPLACEMENT**

D313_EN_17_05/2026

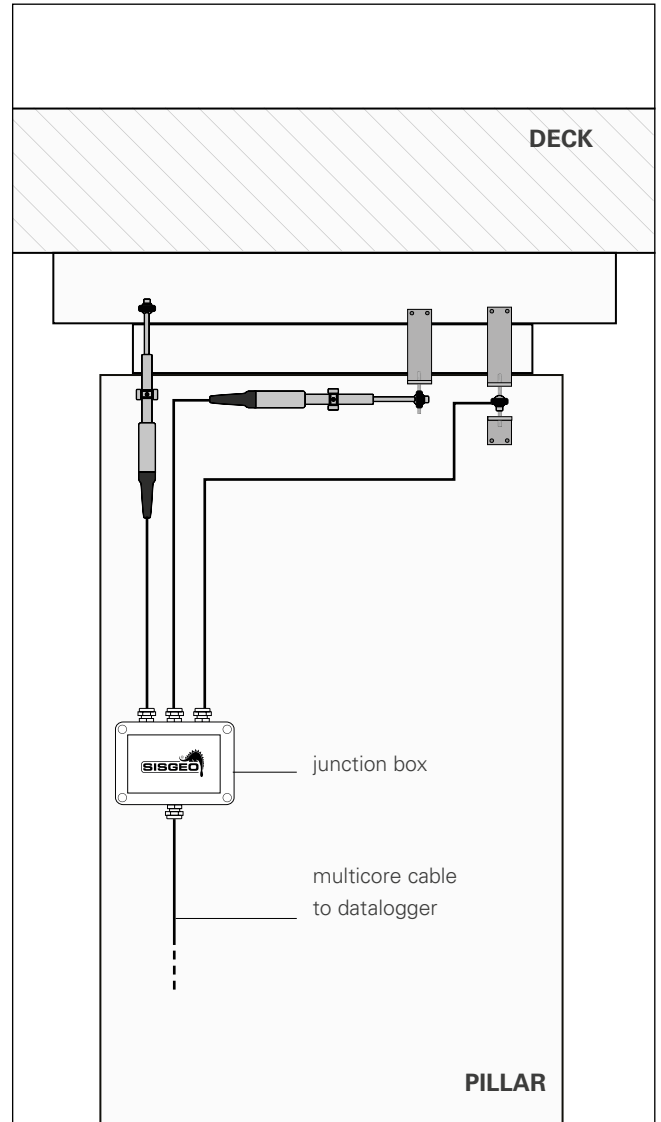
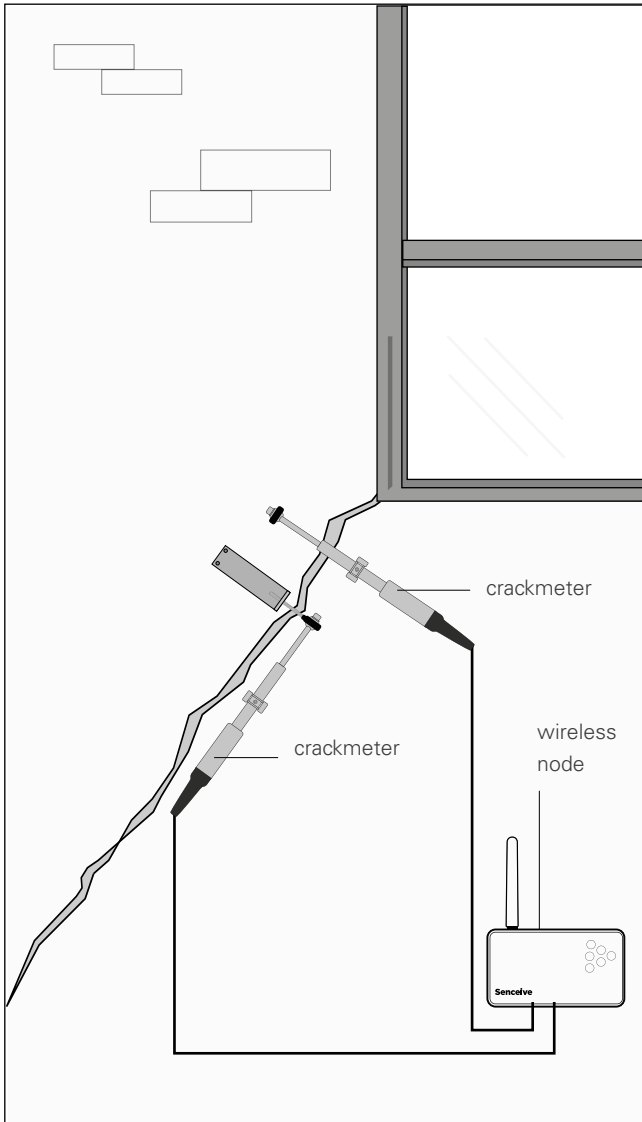

READABLE BY

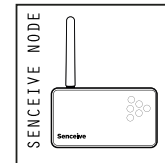
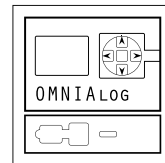
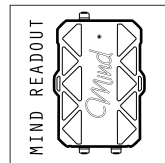
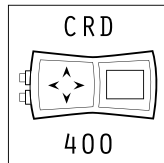

For further information, refer to the relevant readout datasheets.

All information in this document is the property of Sisgeo S.r.l. and shall not be used without prior written permission from Sisgeo S.r.l. The manufacturer reserves the right to modify the product and/or its components without prior notice, including due to supply constraints not related to the technical characteristics. For instrument-specific metrological performance, refer to the individual Calibration Report supplied with each sensor. See Installation & User Manual for installation, commissioning and maintenance procedures. This datasheet is issued in English and in other languages. To avoid discrepancies in interpretation, Sisgeo S.r.l. declares that the English version prevails.

SISGEO S.R.L.

VIA F. SERPERO 4/F1
20060 MASATE (MI) ITALY
PHONE +39 02 95764130
FAX +39 02 95762011
INFO@SISGEO.COM

TECHNICAL ASSISTANCE

SISGEO offers technical support by e-mail to ensure correct installation and use, and to maximize system performance. For further information, contact: assistenza@sisgeo.com