

S543

— 360°  
TILTMETER

INCLINOMETERS  
& PENDULUMS

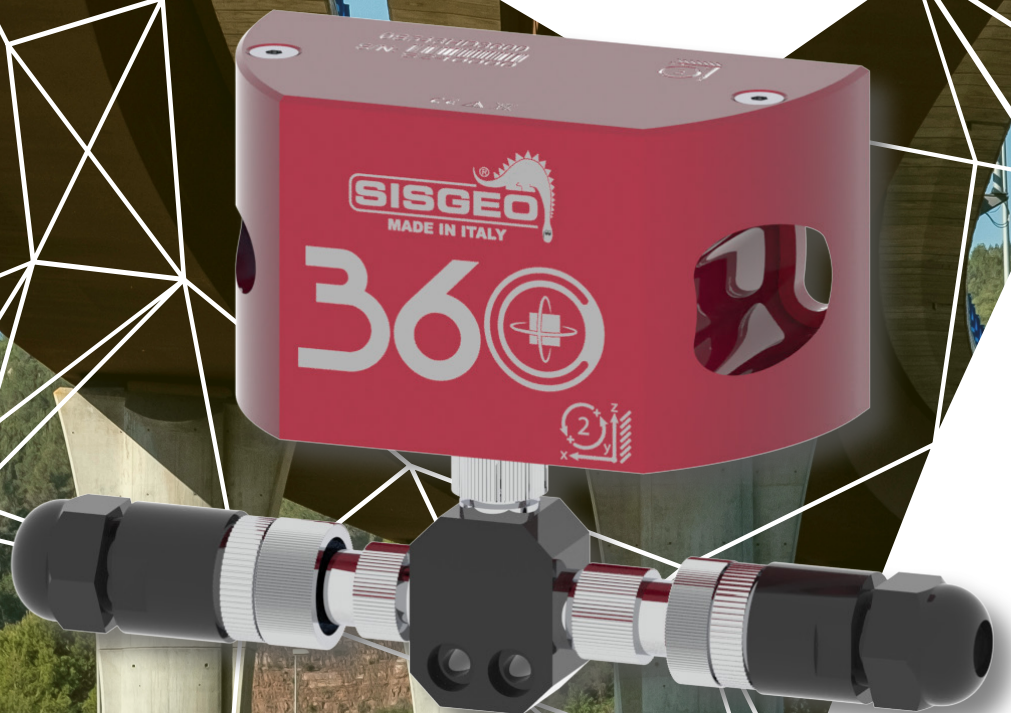



## 360° TILTMETER

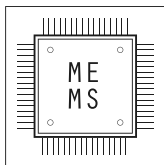

The measurement of inclinations is essential for the control and security of structures in elevation, both during the construction phase and in operation.

Innovative 360° technology, allows each tiltmeter to be calibrated over the full 360° range on three axes. This allows the instruments to be installed in any orientation in space with no effect on measurement quality, simplifying installation operations.

Tiltmeters can be read with MIND portable readout, wireless digital node, OMNIAlog datalogger or any Modbus Master programmed with Sisgeo protocol.

### MAIN APPLICATIONS

- SHM (Structural Health Monitoring)
- Building safety along adjacent excavations
- Diaphragms and retaining walls
- Historical buildings
- Decks and bridge piers

### FEATURES

- 360° range with calibration on whole FSR
- IP65 class protection
- High performances
- Minimal temperature dependency

**CE** Meet the essential requirements of the EMC Directive 2014/30/UE

## WORKING PRINCIPLE

The sensor utilized in 360 tiltmeters is a triaxial MEMS accelerometer. The three axes x, y and z of the MEMS sensor define three planes ZY, XZ and YX generated by the pairs of axes zy, xz and yx. MEMS sensors can measure accelerations along the x, y, and z axes, which are then used to calculate the instrument's tilts.

In the three next pictures, the tiltmeter is installed on a vertical wall (refer to vector "g") so that the z axis is **vertical**. In this position, the MEMS sensor will be able to measure the rotations of the ZY and XZ planes, while it will NOT be able to measure the rotations of the YX plane (perpendicular to the acceleration of gravity "g"). The rotations of the three planes ZY, XZ and YX are defined by the numbers 1, 2 and 3 corresponding to channels 1, 2 and 3 of the instrument output.

So, with tiltmeter installed on a vertical wall as in the next pictures, channels 1 and 2 of the tiltmeter will give the rotation of the ZY and XZ planes, while channel 3 will return no data (channel automatically disabled). Channel 3 will remain disabled if the inclination of the YX plane relative to the horizontal is less than 40° or greater than 140°. In this way, the stated accuracy performance can be guaranteed.

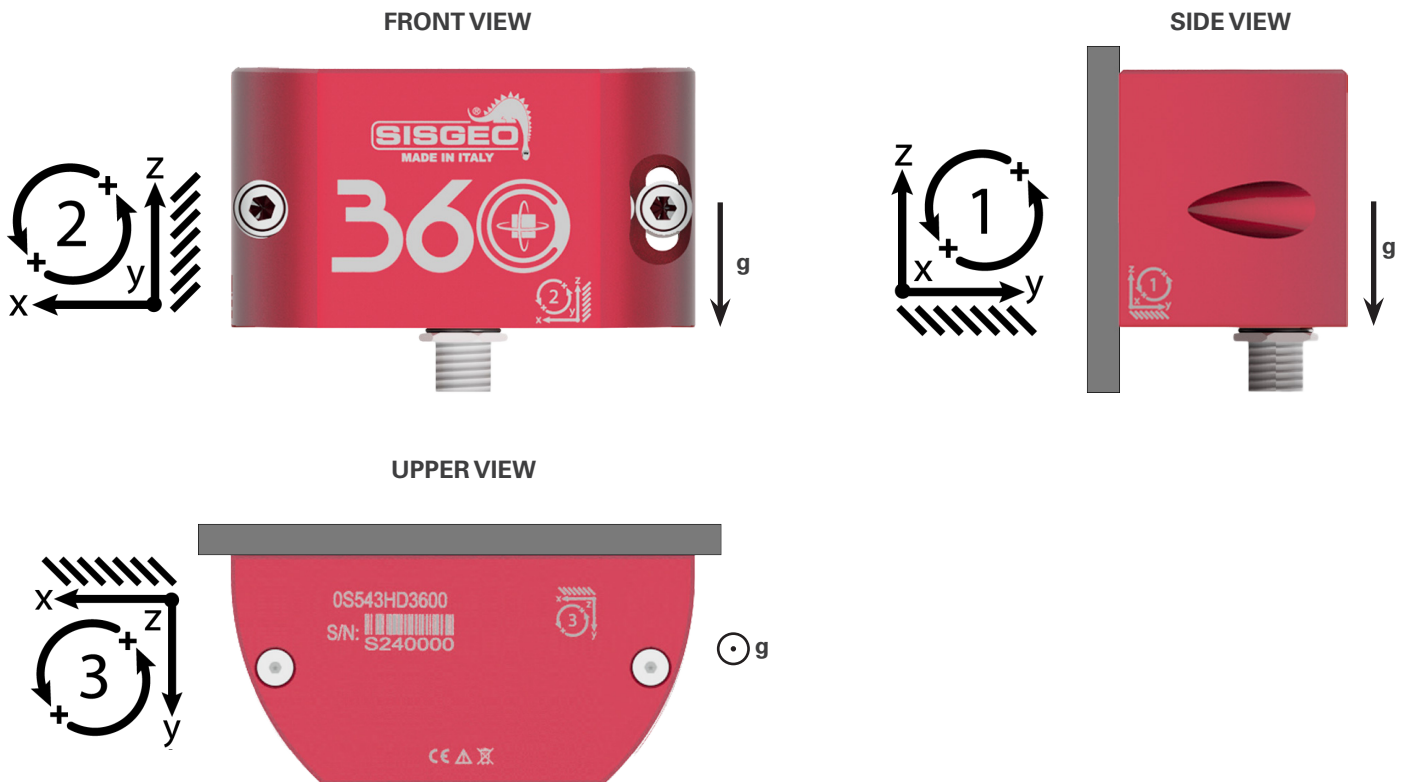

If the tiltmeter is installed on a **horizontal** surface such that the y-axis is vertical and parallel to g, the data returned by the tiltmeter will be on channel 1 (ZY plane rotation) and channel 3 (YX plane rotation), while channel 2 will return no data (channel automatically disabled, as described before for the vertical application).

With this configuration, by simply reading channels 1 and 2, or 1 and 3, the tiltmeter can cover most of the required installation types (vertical or sub-vertical walls, and horizontal or sub-horizontal surfaces). In addition, due to calibration over the entire 360° range on all axes, there is no need for careful positioning of the instrument with support plates that could affect the quality of readings.

The 360° tiltmeter, in parallel to the rotations of the main planes on channels 1, 2 and 3, also outputs the inclinations of the ZY, XZ and YX planes with respect to gravity acceleration g on channels 4, 5 and 6. These data can be used in the case of complex monitoring, such as for tiltmeter alignments on a circumferential arc. For more information, please refer to the instrument's user manual.

The 360 tiltmeter gives also the values of the calibrated components of gravity accelerations  $g_x$ ,  $g_y$  and  $g_z$  on channels 7, 8 and 9. This is in keeping with Sisgeo's view of complete data transparency.

## TECHNICAL SPECIFICATIONS

PRODUCT CODES	0S543HD3600
Measurement principle	Triaxial MEMS accelerometer
Measuring range	<b>360° (±180°) on all three axes</b> (see "WORKING PRINCIPLE")
Repeatability	<± 0.001°
Resolution	0.0001°
Sensor mechanical bandwidth	1 Hz
Stability @ 24 hours	<± 0.004°
Sensitivity <sup>(1)</sup>	see Calibration Report
MPE Accuracy <sup>(2)</sup>	<±0.02° (<±0.0055% FSR @360°)
Offset temperature dependency	±0.002° / °C
Power supply	from 8 to 28 Vdc
Signal output and protocol	RS485, Modbus RTU <sup>(3)</sup>
Average consumption	3.7 mA @ 24 Vdc, 7.0 mA @ 12 Vdc
Temperature operating range	from -30°C to +70°C
Internal temperature sensor	Embedded on electronic board
- measuring range	- 40°C to +125°C
- accuracy (resolution)	±1°C with temperature range -10°C to +85°C (res. 0.01 °C)
Internal humidity sensor <sup>(4)</sup>	Embedded on electronic board
- measuring range	0 to 100% RH
- accuracy (resolution)	±5% RH with humidity range 0 to 95% RH (res. 0.025% RH)
On-board supply voltage monitor <sup>(4)</sup>	Embedded on electronic board
- measuring range	0 to 36 V
- accuracy (resolution)	±5% FS (res. 0.01 V)
IP Protection class	IP65
Material	Gauge body: anodized aluminum
Fixing support	N.2 anchor bolts M6
Signal cable	0WE106IP0ZH
Cabling	M12 male connector on sensor body, 3-port T-shaped splitter with 2 female and 1 male connectors
Max. cable length to logger	1000 m (for more information see <a href="#">FAQ #073</a> ) <sup>(7)</sup>

(1) Sensitivity is a specific parameter different for every gauge. The sensitivity is calculated during gauge calibration test and inserted into the Calibration Report.

(2) MPE is the Maximum Permitted Error on the measuring range (FSR). In the Calibration Report, the accuracies of the gauge are calculated using the linear regression; the error reported is the maximum residual error on the FSR on the three axis

(3) RS485 not-optoisolated Modbus communication with RTU Protocol Default output is degree. Sisgeo Modbus protocol manual is available for download on Sisgeo web site.

(4) These sensors are installed on the internal electronic board to give information in the event of probe malfunction.

(7) Refer to FAQ section on Sisgeo website: [www.sisgeo.com/faq](http://www.sisgeo.com/faq)

## PHYSICAL FEATURES

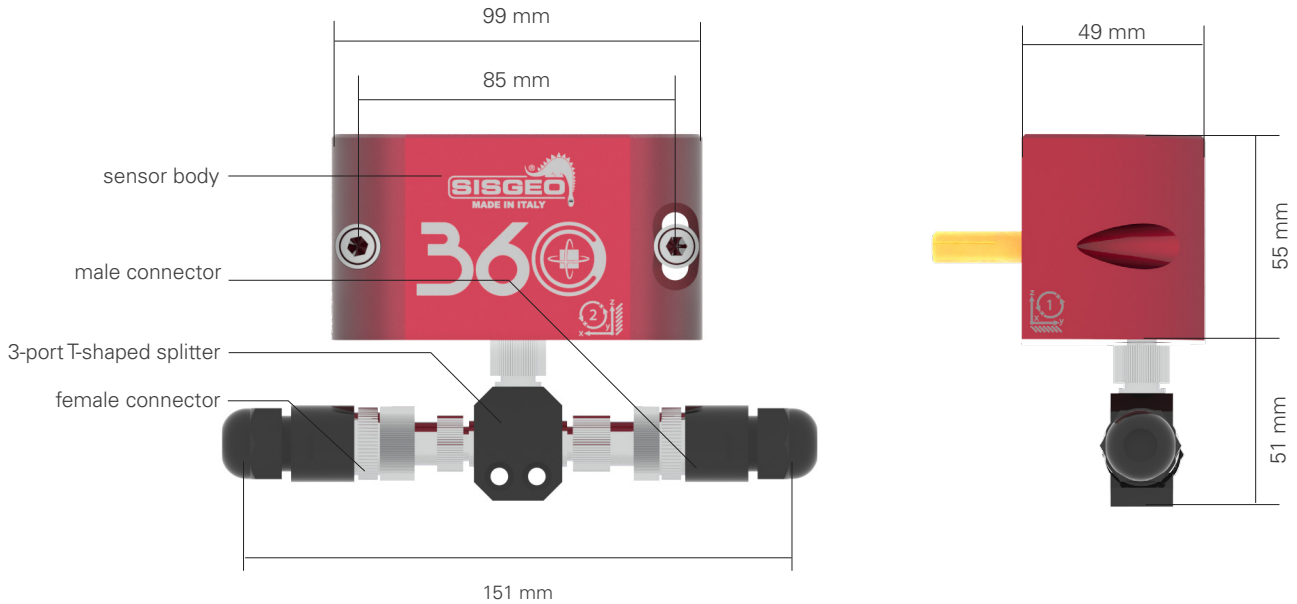

## ACCESSORIES AND SPARE PARTS

### RESISTANCE ENDING DEVICE OETERMRESIO

Termination resistance with connector, needed to close every digital instrument chain. The value of resistor depends on the layout of each monitoring system.  
For more detail see the [FAQ#076](#).

### RESISTANCES KIT (SPARE) OERESIKIT00

Spare kit consisting of one 120-ohm resistor, two 240-ohm resistors, three 360-ohm resistors, and four 480-ohm resistors. Each resistance has a 5-pin M12 connector for connection to SISGEO digital gauges. Check with your sales representative for compatibility with older digital gauges.

### CONNECTORS KIT (SPARE) OECON05T3K0

Spare connector kit for tiltmeters. The kit consists of three 3-port T-shaped splitter, three female connectors and three male connectors.

## READABLE BY

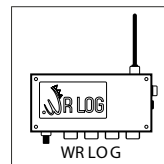
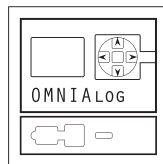
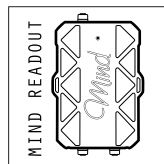

All the information in this document is the property of Sisgeo S.r.l. and should not be used without permission from Sisgeo S.r.l. The manufacturer reserves the right to make changes to the product or to its parts without prior notice, also on the basis of contingent situations not related to the technical characteristics alone, such as, for example, material or components shortages. For the specific accuracy performance of each product, please refer to the Calibration Report issued for each instrument. The datasheet is issued in English and other languages. In order to avoid discrepancies and disagreement on the interpretation of the meanings, Sisgeo Srl declares that English Language prevails.

### SISGEO S.R.L.

VIA F. SERPERO 4/F1  
20060 MASATE (MI) ITALY  
PHONE +39 02 95764130  
FAX +39 02 95762011  
INFO@SISGEO.COM

### ADDITIONAL SUPPORT

SISGEO offers on-line assistance service to the Customers in order to maximize the performance of the system and training on the correct use of the instrument/readout.

For more information contact mail: [assistance@sisgeo.com](mailto:assistance@sisgeo.com)